

# POWERSCREEN® CT50

TRACKED CONVEYOR

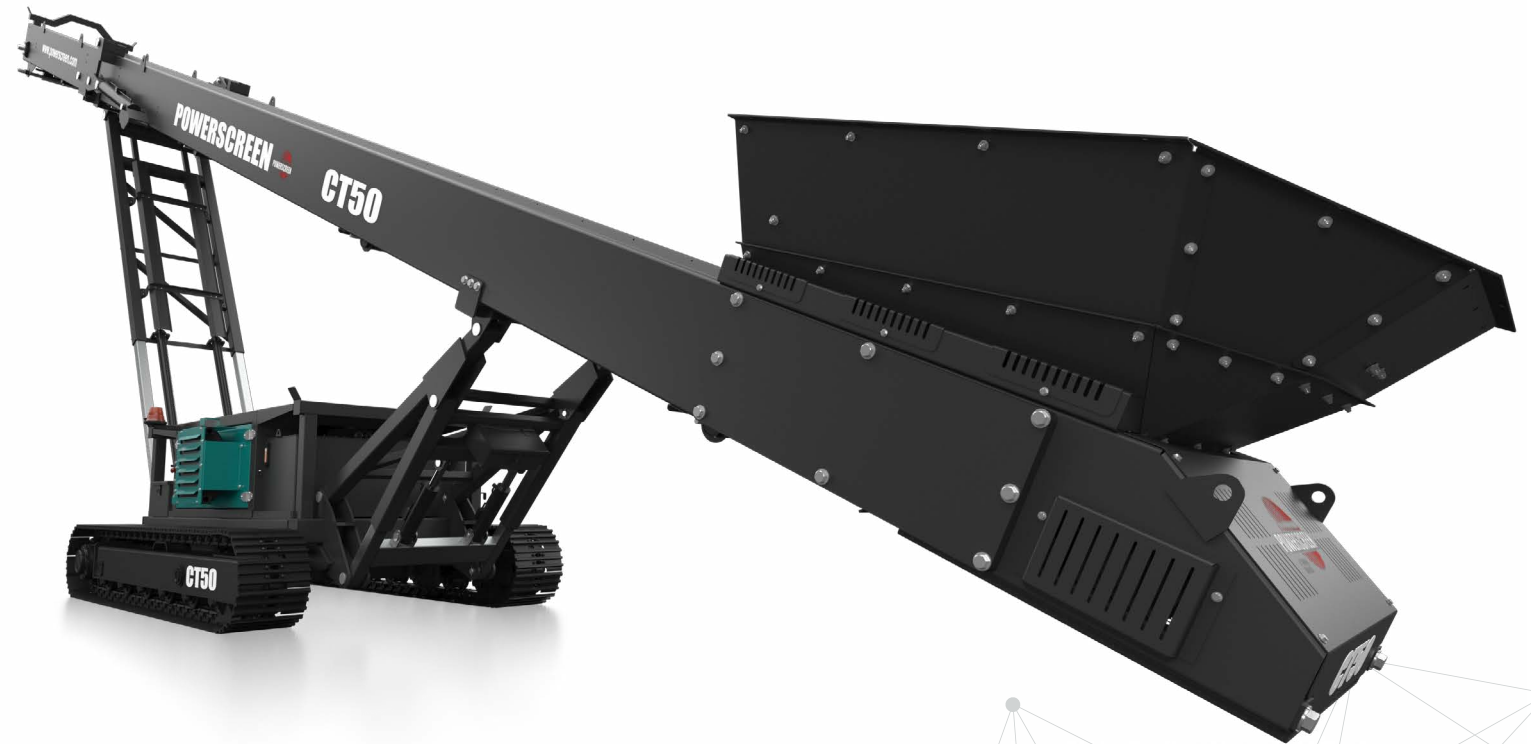

TECHNICAL SPECIFICATION - REV 0 01/04/2025





## CT50 TRACKED CONVEYOR



# OVERVIEW

### SPECIFICATION

<b>Total Weight</b>	8,000kg (17,637lbs)
<b>Transport</b>	<b>Length</b> 11.87m (38' 11")
	<b>Height</b> 2.69m (8' 10")
	<b>Width</b> 2.24m (7' 4")
<b>Working @ 24°</b>	<b>Length</b> 14.96m (49' 1")
	<b>Height</b> 6.93m (22' 9")
	<b>Width</b> 2.24m (7' 4")
<b>Power Unit</b>	Tier 3: Cat C2.2 37kW (50hp) or, Tier 4F: Cat C1.7 37kW (50hp) or, Stage V: Cat C1.7 37kW (50hp)
<b>Plant Colour</b>	Blue RAL 5021, Grey RAL 7024

NOTE: Dimensions may differ slightly from sales drawings due to differences in angles / reference points.

### FEATURES & BENEFITS

- High capacity up to 500tph (551 US tph).
- Maximum feed size up to 200mm (7.5").
- Eliminates the need for wheeled loaders to create stockpiles - reduces labour and maintenance costs.
- Eliminates the need for handling material multiple times - reduces labour and maintenance costs.
- Improved material quality due to reduced compaction, degradation, segregation and contamination.
- Can accept loads from multiple sources.
- Multiple hopper options available depending on required capacities and operators loading methods or application.
- Rapid set up time and manoeuvrability around site.
- Reduced fuel consumption due to reduced reliance on wheeled loaders.
- Reduced wear on wheeled loaders where a conveyor is utilised.
- Hydraulic folding head section.
- Tensioned polyurethane belt cleaner.
- Hydraulic feed in height adjustment.
- Hydraulic fold over for transport.
- SCS scraper.
- 45 degree rollers.
- Variable speed conveyor via engine speed.
- Feedboot with removable 6mm steel wear liners.

### APPLICATIONS



#### Aggregate

Sand & gravel  
Blasted rock  
River rock



#### Recycling

C&D waste  
Foundry waste



#### Mining

Processed ores  
Processed minerals



## CT50 TRACKED CONVEYOR



# ↓ FEEDBOOT

<b>Standard Feedboot Capacity:</b>	2.6m <sup>3</sup> (3.4yd <sup>3</sup> )
<b>Standard Feed in Width:</b>	2740mm (9')
<b>Standard Min Feed Height @24°:</b>	1580mm (5' 2")





## CT50 TRACKED CONVEYOR



# DISCHARGE CONVEYOR

<b>Width:</b>	900mm (36")
<b>Belt Centres:</b>	15.24m (50')
<b>Belt Type:</b>	Plain
<b>Belt Spec:</b>	EP300 3PLY
<b>Drive Drum Dia:</b>	344mm (14")
<b>Tail Drum Dia:</b>	275mm (11")
<b>Max Belt Speed:</b>	180m/m
<b>Motor Size:</b>	500cc
<b>Operating Angle:</b>	0° - 24°
<b>Discharge Height @18°:</b>	5.79m (19')
<b>Stockpile Capacity @18° &amp; 37° Angle of Repose:</b>	358m <sup>3</sup> (468 Cu.Yd)
<b>Discharge Height @24°:</b>	6.93m (22' 9")
<b>Stockpile Capacity @24° &amp; 37° Angle of Repose:</b>	613.8m <sup>3</sup> (802.8 Cu.Yd)
<b>Variable Speed:</b>	Via engine speed





## CT50 TRACKED CONVEYOR



# ↓ TRACKS

<b>Shoe Width:</b>	400mm (1' 4")
<b>Sprocket Centre:</b>	2490mm (8' 2")
<b>Gradability:</b>	120°
<b>Speed:</b>	2.8km/h





## CT50 TRACKED CONVEYOR



# ↓ POWER UNIT & HYDRAULICS

**Engine (Tier 3):** Cat C2.2  
**Power Rating:** 37kW (50hp)  
**RPM:** 2800rpm  
**Crankshaft Pump:** 33cc

**Engine (Stage V):** Cat C1.7  
**Power Rating:** 37kW (50hp)  
**RPM:** 2800rpm  
**Crankshaft Pump:** 33cc

**Engine (Tier 4F):** Cat C1.7  
**Power Rating:** 37kW (50hp)  
**RPM:** 2800rpm  
**Crankshaft Pump:** 33cc

**Diesel Tank Capacity:** 228L (60 US GAL)  
**Hydraulic Tank Capacity:** 290L (77 US GAL)

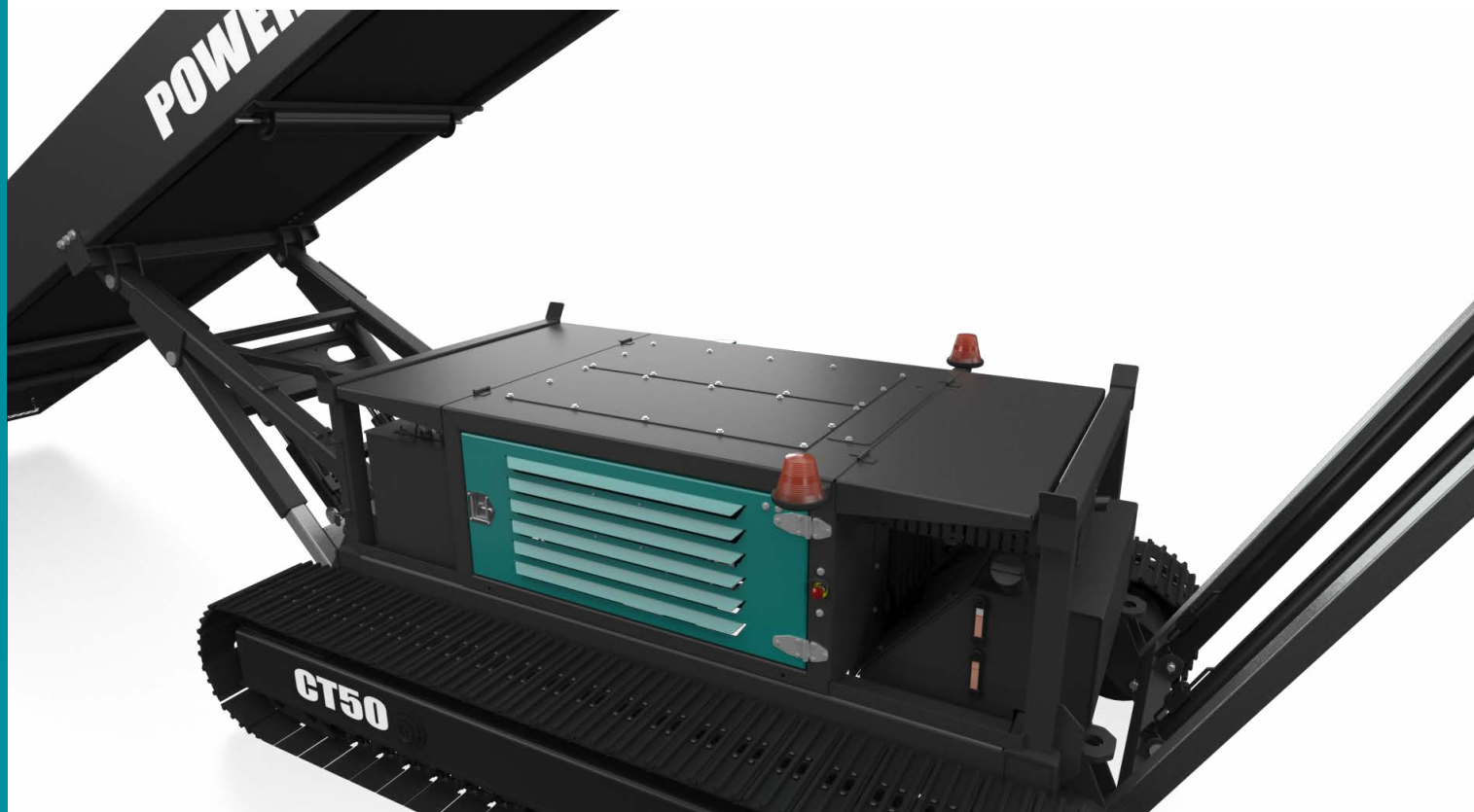



## CT50 TRACKED CONVEYOR



## **OPTIONS**

- Dual Power (Electric/Hydraulic - Diesel/Hydraulic)
- Heavy duty 4 ply belt
- Chevron Belt (C15/C25)
- Front extensions for feedboot
- Rubber lined extended feedboot 10mm or 15mm
- Hardox lined extended feedboot 6mm
- Cordless remote control tracking
- Under guarding Cover
- Basket guards
- Manual jacking legs
- Anti roll back flaps



## CT50 TRACKED CONVEYOR



# DIMENSIONS

Figure 1: Powerscreen CT-50  
Working Position

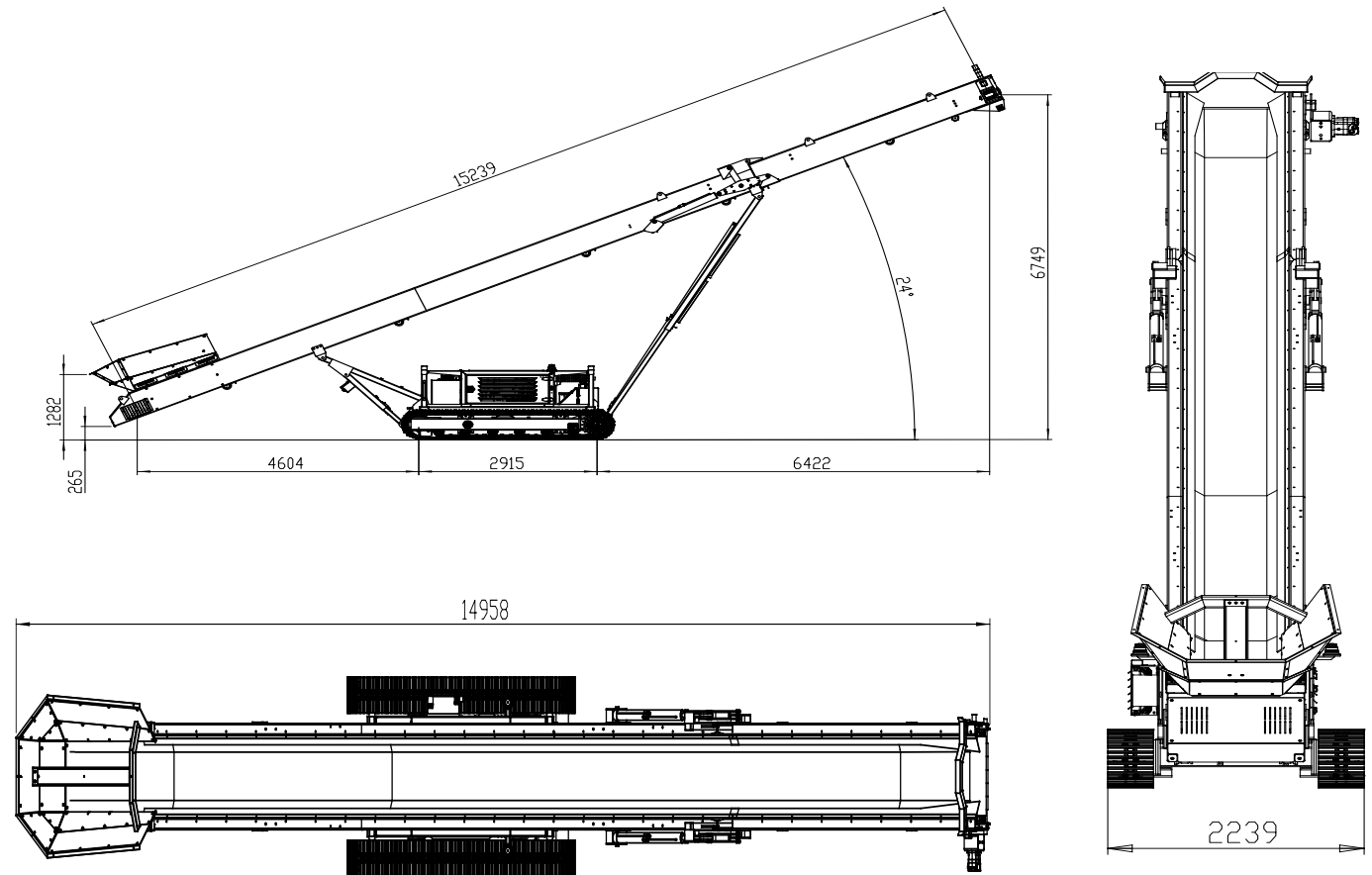

[MORE DIMENSIONS OVERLEAF](#)





# DIMENSIONS

## CT50 TRACKED CONVEYOR



Figure 2: Powerscreen CT-50  
Transport Position

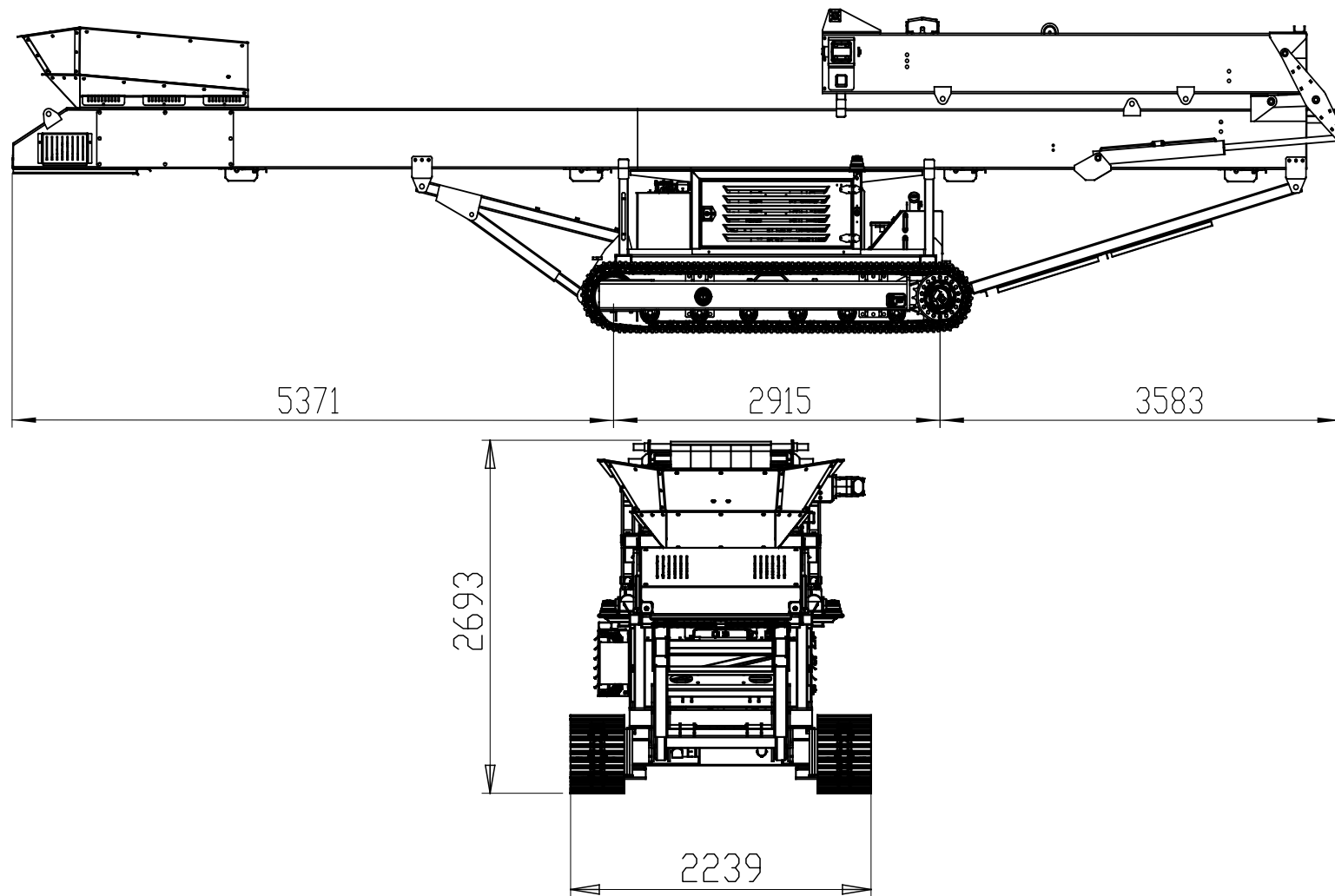



### **Powerscreen equipment complies with CE requirements.**

Please consult Powerscreen if you have any other specific requirements in respect of guarding, noise or vibration levels, dust emissions, or any other factors relevant to health and safety measures or environmental protection needs. On receipt of specific requests, we will endeavour to ascertain the need for additional equipment and, if appropriate, quote extra to contract prices.

All reasonable steps have been taken to ensure the accuracy of this publication, however due to a policy of continual product development we reserve the right to change specifications without notice.

It is the importers' responsibility to check that all equipment supplied complies with local legislation regulatory requirements.

Plant performance figures given in this brochure are for illustration purposes only and will vary depending upon various factors, including feed material gradings and characteristics. Information relating to capacity or performance contained within this publication is not intended to be, nor will be, legally binding.

## **GET IN TOUCH**

### **Dungannon**

200 Coalisland Road, Dungannon,  
Co Tyrone, BT71 4DR, Northern Ireland  
Tel: +44 (0) 28 87 718 500  
Fax: +44 (0) 28 87 747 231

### **Louisville**

11001 Electron Drive,  
Louisville, Kentucky, 40299 USA  
Tel: +1 502 736 5200  
Fax: +1 502 736 5202

